

LANGUAGE & LINGUISTICS IN MELANESIA

Journal of the Linguistic Society of Papua New Guinea ISSN: 0023-1959

Vol. 44, 2026



The phonology of Tuwari: hiatus and allophonic pharyngealization

Noam Faust

Université Paris 8, CNRS SFL

Sylvain Loiseau

Université Sorbonne Paris Nord,
CNRS-Lacito

[Website: www.langlxmelanesia.com](http://www.langlxmelanesia.com)

[Email: langlxmelanesia@gmail.com](mailto:langlxmelanesia@gmail.com)

The phonology of Tuwari: hiatus and allophonic pharyngealization

Noam Faust

Université Paris 8, CNRS SFL

Sylvain Loiseau

Université Sorbonne Paris Nord,
CNRS-Lacito

Abstract: Based on fieldwork data, this paper analyzes key aspects of the phonology of Tuwari, a previously undescribed Papuan language. Like many Papuan languages, Tuwari has a small phonemic inventory and simple syllable structure, lacking codas but permitting onsetless syllables. We argue that despite the limited consonant inventory, several phonetically salient sounds—such as glides and laryngeal or pharyngeal consonants [ʔ, ʕ]—are not phonemic in Tuwari. The glides represent non-nuclear versions of vowels, with the laryngeal and pharyngeal segments arising from the vowel /a/ (and, more rarely, /ɔ/ or /ɛ/). Both phenomena reflect hiatus resolution strategies, which are pervasive due to the interaction of onsetless syllables with a strong avoidance of hiatus. Notably, the pharyngeal consonant reported here has not previously been documented in Papuan languages. We further argue that many surface consonant clusters result from the non-realization of underlying vocalic positions—either through syncope or underapplication of vowel epenthesis. The clusters that do surface correspond primarily to the least marked types cross-linguistically: obstruent-liquid “branching onset” clusters and sonorant/sibilant–obstruent “coda-onset” clusters.

Keyword: Tuwari, Papuan languages, hiatus, syncope, glide, pharyngeal consonant

1 Language Background

The Tuwari language is a Papuan language spoken by 300 speakers (personal estimate) in the Sandaun province of Papua New Guinea. It exhibits many common typological properties of Papuan languages, such as a restricted phonemic inventory, complex verb morphology (in contrast with the nominal domain), SOV constituent order, a marked preference for a small number of overt arguments per clause, a serial verb construction and a clause chaining construction (Foley 1986, Evans and Fedden to appear). It also has a gender system of 12 values triggering anaphoric agreement on several targets and a phrasal clitic article on nominal expressions at the clause level. Tuwari has no switch reference system. This paper concentrates on the phonology of the language.

2 Basic facts

Tuwari phonology is noteworthy for the following traits. First, it has an extremely small phonemic inventory, with lenition applying to most consonants intervocalically. Second, despite the size of its inventory, most of the contrastive functional load is carried by segments: Tuwari does not make use of tone, stress or segment length to distinguish between words. Third, vowel-zero alternations often occur in the language if the surrounding consonants can become branching onsets or high sonority codas. Fourth, and possibly most unique, is the treatment of the many hiatuses that occur in the language, and specifically the non-lexical voiced pharyngeal approximant [ʕ] used to resolve certain hiatuses. To the best of our knowledge, this phenomenon has not been reported for any language, Papuan or not.¹

This study is based on a medium size lexicon of ~2000 different forms previously compiled, and on a new narrow phonetic transcription of 17 texts (for a total of ~3000 words). The texts and lexical facts were elicited from 6 speakers of various ages (5 males and one female) by the second author during several field trips between 2013-2019. The texts are spontaneous recollections of different events in the lives of the speakers.²

In what follows, we first describe the phonemic and phonetic inventories of the language. Then we explore vowel-zero alternations and hiatus resolution strategies. Finally, we comment on stress and conclude.

2.1 Consonants

A phonemic analysis of Tuwari yields 9 consonants. Bilabial and coronal places of articulation distinguish oral stops, fricatives and nasals. There is also a coronal liquid. The coronals are apical. The remaining two consonants are the velar stop and the glottal fricative. For the sake of symmetry, these can be grouped together; though there is no clear-cut reason beyond this symmetry to do so.

(1) Consonant inventory

	Bilabial	Coronal	Palatal	Velar	Glottal
Stop	p	t		k	
Fricative	ɸ	s			h
Nasal	m	n			
Liquid		l			
Approximant	(w)		(j)		

¹ One of the authors has much experience studying the pharyngeal sounds of Semitic languages; the [ʕ] found in Tuwari is phonetically identical to the one found in those languages.

² At the time of writing of this paper, the corpus is being prepared for online posting on the Pangloss language archive.

Approximants are arguably not phonemic. Indeed, below we will claim that there is no contrast between glides and vowels. The elimination of /j/, specifically, from the consonantal phoneme inventory is satisfying in terms of the symmetry of the system, as it is the only palatal sound.

Given the above, a more abstract analysis, based on standard, distinctive features leads to the table in (2). Place of articulation is specified for being [\pm posterior] and [\pm labial], such that coronals are the least marked. As for manner, consonants are either sonorant or not. Non-sonorant consonants are specified for [\pm continuant], and sonorant ones are specified for [\pm nasal]. The cells occupied by “-” are either articulatorily impossible for [+consonantal] sounds (a non-nasal bilabial sonorant) or universally marked (posterior sonorants). The least marked consonant is therefore [t].³

(2) Consonant inventory: reduced

		-posterior		+posterior
		+labial	-labial	
-sonorant	-continuant	p	t	k
	+continuant	ϕ	s	h
+sonorant	-nasal	-	l	-
	+nasal	m	n	-

There is considerable allophonic variation in some consonants, but not in others. Most commonly, one finds intervocalic lenition. /p,t/ are realized as voiced [b,d] between vowels. In some occurrences, they may even be pronounced spirantised as [β,δ], though this is rarer. Similarly, / ϕ / is often realized as voiced [β] intervocalically. Word-initially, the bilabial fricative is often heard as a labiodental [f], but there are very few lenited variants [v]. The coronal fricative /s/ is pronounced in the region of [\underline{s}], i.e. a retracted alveolar, as is common in languages that do not distinguish more than one sibilant (Kokkelmans 2021). Intervocalically, this sound is also commonly realized as a voiced [\underline{z}].

(3) Consonantal allophony

	Bilabial	Coronal	Palatal	Uvular	Glottal
Stop	p,b, β	t,d, δ		q,k	
Fricative	ϕ ,f, β	s,z (ζ)			h
Nasal	m	n			
Liquid		l,r,j			
Approximant	(w)		(j)		

³ Our features here are based on Jason Riggle’s (2011) table of distinctive features, with one deviation. We use [posterior] instead of [anterior], because posterior consonants are consistently more marked than anterior ones (see for instance Kokkelmans 2021 for sibilants). Using [anterior] would amount to designating [+ant] [t] as more marked than [-ant] [k].

The lateral sound /l/ oscillates between [l] and [ɾ] intervocalically. The [ɾ] realization is obligatory when /l/ is the second consonant of a branching onset. Word-initially, only [l] is attested.

- (4) /wɑɸlɔ/ [wɑɸrɔ] ‘lay down’
 /sɛrɛ/ [sɛrɛ] ‘plastic’

For some speakers, /l/ can be further lenited in unguarded speech into [j], especially next to [i], e.g. /sinali/ => [sinaji] ‘sweet potato’. Intervocalic lenition applies across word boundaries. It also applies to both parts of branching onsets, such that an intervocalic /pl/, for instance, is regularly realized either [br] or [βɾ]:

- (5) /aplo/ [ʃabra] ~ [aβrɔ] ‘finish, CMPL’

Surface codas are extremely rare in Tuwari, and are always the result of syncope. Owing to this rareness, it was not possible to ascertain which allophone occurs in this position. See section 3 for more information.

Interestingly, the posterior consonants exhibit little variability: /h/ only rarely disappears and /k/ never voices or spirantizes. But while /h/ is nearly always realized [h], /k/ does exhibit two allophones: [q] and [k]. [k] tends to occur before high vowels, and [q] occurs before low ones, or sometimes before mid-vowels:

- (6) /kemia/ [qəmja] ‘pandanus’
 /kɔ-pɛ-ma/ [qɔpema] ‘on the bed’ (‘top-bed-DIR’)
 /kokua/ [qokuwa] ‘bad’
 /kiau/ [kiawu] ‘egg’

Finally, nasals /m/ and /n/ do not exhibit allophony. They maintain their place of articulation even when, due to syncope, they end up being adjacent to the following consonant:

- (7) /mɛ-tɔ-si-nami/ [mtosinami] ‘having cut’ (‘SEQ-cut-DUR-after’)

As will be explained in 3.3 below, some hiatuses (and some initial onsetless syllables) are optionally repaired with a glottal [ʔ] or a pharyngeal [ʕ]. Since these two sounds occur only when followed by low vowels, and always optionally ([maʃawɔ] ~ [maʔawɔ] ~ [maawɔ] /maawɔ/ ‘fish sp.’), they are plausibly epenthetic.

2.2 Vowels

There are five vowels in Tuwari; /a, i, u, ɛ, ɔ/. The vowel /a/ is sometimes pronounced long, but we have not found minimal pairs, and the same item can be pronounced with a long or a short [a]. We have noticed

two qualities of the vowels /i/ and /a/, approximately [ɪ] and [i] and [a] and [ɒ]. But we have not found minimal pairs, and the difference seems to disappear in careful speech in favor of [i] and [a].

Five vowel systems are described in Element Theory (Kaye et al. 1985, Backley 2011) using the three basic elements [A,I,U]. These correspond to the vowels /a,i,u/. [A] can combine with the other two, giving the mid vowels /ɛ,ɔ/.⁴

(8) Vowel inventory

	-posterior	+posterior	
	-round		+round
-low	i I		U U
+low	ɛ IA		ɔ UA
		a A	

Mid vowels /ɛ/ and /ɔ/ are often realized as semi-closed [e] and [o] when unstressed, that is when not final in the phonological word (stem+suffixes/clitics). Occasionally, the reduction in this environment takes a further step into [ə]. The reduction to [e,o] does not seem to occur in at least two environments: i. after the back consonants [h,q]; and ii. preceding the final, stressed [ɛ,ɔ]:

(9) /ufɔfɔ ɔj/ [ufəfəɔʒj] ~ [ufəfəɔʒj] ~ [ufɔfɔɔʒj] ‘fish.sp. DET’

The mid vowels /ɔ,ɛ/ are sometimes realized as [a] when adjacent to pharyngeal [ʕ] (even across words). Note that this change can occur in the word-final position, too, if the following word begins with [ʕ]:⁵

(10) /ɔpɔ ani ɔi/ [ɔpa ʕani ʕɔj] ‘bird bird.sp. DET’
 /sineɛ/ [sinaʕa] ‘vegetables’
 /hejtɔmu-lɛ ʕanɔ-mu lɔ-mɛ-lɛ-iɔ/ [hedəmla ʕanomulomɛɛjo]
 ‘[we] are hungry’ (‘food want do-TOP-PL-FIN’)

Below, we will propose that pharyngeals are not phonemic. From a rule-based perspective, it is therefore implied that first the pharyngeal is formed, and then lowering occurs.

We also have cases where there is no such change:

⁴ Analyzing the system in terms of element is important to the specific phonological analyses below. Consonants can also be analyzed using Element Theory, but that analysis is quite abstract, so we decided to avoid it here.

⁵ Listening to the accompanying recording, a reviewer suggests that /ɔ/ can be realized as a low, rounded [ɒ] word-finally, even without an adjacent [ʕ].

- (11) /miɔ-əple-nami/ [miɔʁaβinami] ‘down-CMPL-after’
 /uea/ [weʁa] ‘mountain’

If no pharyngeal appears, the vowels will not change.

We propose to regard the process of [ʁ]-formation on a par with glide formation. In Element Theory (Kaye et al. 1985, Backley 2011), as already stated above, there are three basic vocalic elements |I,U,A|, which give rise to the basic three vowels [i,u,a]. In addition, there can be combinations of two elements, such that |I+A| = [e], |U+A| = [o]. The elements |I,U| yield [i,u] or [j,w] depending on their association to a nucleus or a non-nucleus respectively. In Tuwari, this would apply to |A| as well, with the non-nuclear realization of |A| being [ʁ]. Thus, in (12a), the hiatus is avoided by the association of the second vocalic expression to the root node of the middle C-position ([ʁ] could in principle originate in the first vocalic expression; we will claim below that phonological features are preferably shared within the syllable). This representation is somewhat problematic, as it positions the entire expression |A+I| - the mid vowel - in the C-slot. Possibly because of this, the element |I| is optionally delinked, and the |A| comes to have both the onset and the nucleus following it all to itself, as in (12b). Example (12c) is the exact opposite of (12b), where the first vowel provides the glide. Example (12d), in turn, shows how one element A can occupy both Vs, as well as the intermediary C.⁶

- (12) Realizations of /sɛ-ɛ/ ‘DEM-DET’ => [saʁa]

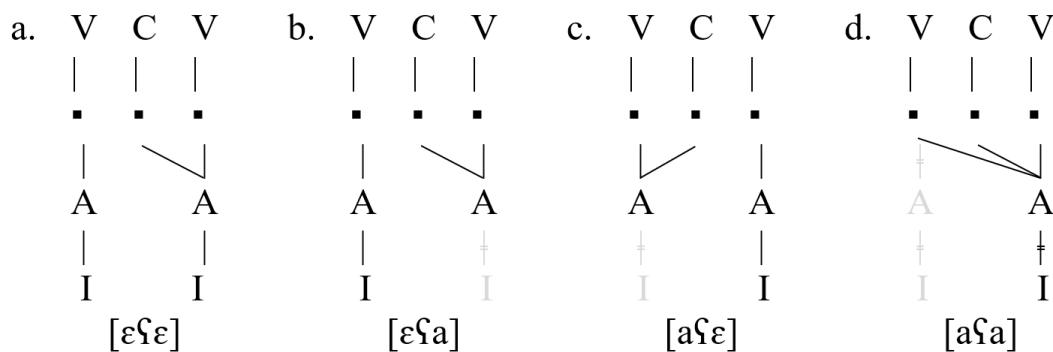

This alternation is discussed further in section 3.3 below.

The vowel /ɛ/ is sometimes reduced to [i], as in the second occurrence of /me/ ‘go’ in the following example:

- (13) /me-ia-sɛ opsono-ma me-ia toφu-ia/
 [me-ja-sɛ opsono-ma mi-ja toφu-wa]
 go-PST-DUR village-DIR go-PST arrive-PST
 ‘We walked and arrived to the village’

⁶ It is standard in Element Theory to consider that |A| is involved in gutturals (see e.g. Lowenstamm & Prunet 1985, Angoujard 1996). A parallel between glides and gutturals is proposed in Faust & Lampitelli (2026).

This reduction might be a correlate of stress, though we cannot say this for certain.

Front rounded vowels [œ,y] occur through interactions between vowels. For instance, the sequence /εσεilε ɔwɔ/ ‘drink water’ can be pronounced [esejlε ɔwɔ] or as [esejlœ ɔwɔ] (note that the position of the affected vowel is the word-final one). More commonly, one finds high back /u/ fronted to [y]. This occurs in particular in stem-final position before the suffix /iɔ/. Note that the glide of the suffix also undergoes rounding:

- (14) a. /φuɔlu-iɔ/ b. /φειu-iɔ/
 [φuworyɔ] [φejyɔ]
 spit-FIN throw-FIN
 ‘he/she spits’ ‘he/she throws’

The sequence /u-iɔ/ can also be pronounced [uwo], with complete loss of the frontness of the underlying /i/, presumably, due to the fact that it is also followed by a round vowel. Gliding of /i/ into [w] is not possible when the following vowel is not round, as it would imply a mismatch of both rounding and frontness between the two last underlying vowels *[uwe], *[uwi]. As far as we can tell, the affected vowel is always the first of two interacting vowels.

Following up on our representations of vowel lowering and unrounding, we provide a short account of the alternation in the shape of /i/. Within Element theory, [y,ɥ] are the realization of an expression combining |I+U|, in nuclear and non-nuclear positions respectively. The representation in (15a) is presumably problematic because it has a front unrounded |I| between two round |U|s – we found no such sequences in our corpus. In (15b), the second |U| combines with its onset |I|, such that both the nucleus and the glide are both front and rounded (the progressive spread is motivated by the second vowel being mid). That the element |I| proceeds to combine with the preceding vowel and front it is possibly a result of the invasion of its position by |U|. However, the situation in (15b) is also problematic, if only because it combines |I| and |U| - an uncontroversially marked configuration yielding a front rounded vowel. In (15c) this is resolved by completely delinking the medial |I|. For completeness, note that a sequence /εiɔ/ such as in (15d) can be faithfully realized since the medial /i/ is not flanked by round vowels.

- (15) Realizations of /uiɔ/, /φuɔlu-iɔ/ => [φuwolyɔ] ‘he/she spits’

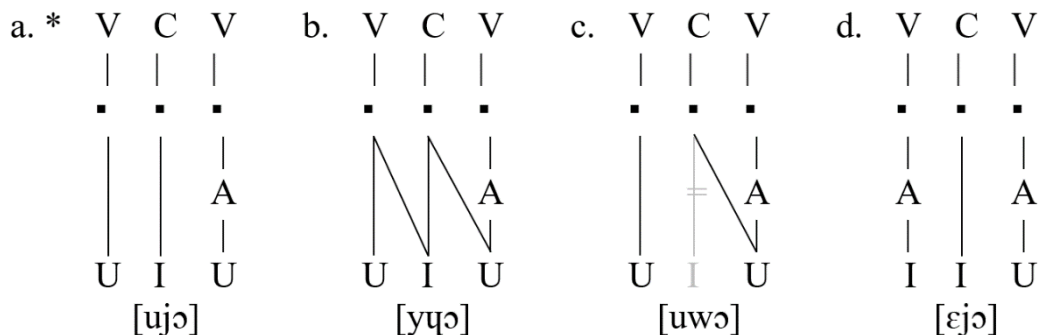

Note that in accordance with our general proposal, (15a) is already a derived form, in that [j] is originally a vowel /i/.

Another problematic configuration, for the same reason, is /ɔio/, which is regularly realized [ɔwɔ], but can also yield [œɸɔ]. As shown in (16a), this configuration initially poses the same problem as (15a). Intrusion of the nuclear |U| may push the |I| toward the preceding nucleus (16b); but much more often, one again finds the complete dissociation of |I| in (16c), with the rounding of the mid vowel imposing a realization [w] of the intermediate onset.

(16) Realization of /ɔio/, favoring roundedness (/ano-io/ ‘search-FIN’ => [anowo])

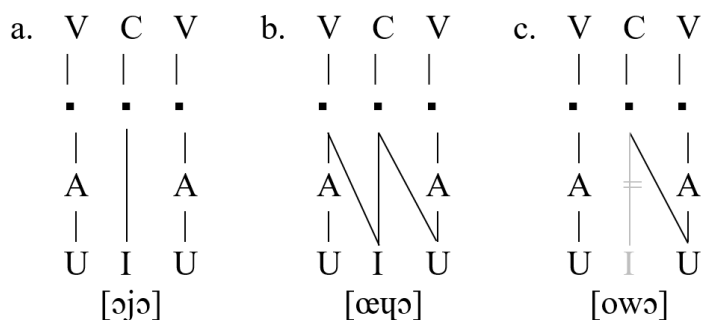

Two aspects of these facts are worth mentioning here. First, the variable realization of sequences like /uiɔ/ can be taken to argue for the proposal that syllabification is an online, articulatory issue. Second, even though we have presented |I| as delinking completely in (15c) and (16c), it seems that the height of the expected glide [j] is still preserved in the output [w]: true /ɔɔ/ sequence are broken by [ʕ], not [w], e.g. /sumɔɔ/ => [sumɔʕɔ] ‘rain’. A full account of this phenomenon would require introducing other aspects of Element Theory; we prefer to leave it as it stands.

The fronting effect was also found in some simplex words, such as [otyɸɛ] ‘food’. We hypothesize this form is underlyingly /ɔtɸiɛ/, and the sequence /ui/ is realized fused, as in (15b) above. If this analysis is correct, this form shows that the underlying front /i/ need not occur between two round vowels in order to undergo rounding; it suffices that it follow a round vowel.

We have also found words such as the reduplicated [tɸyɸɛ] ‘bird sp.’, with no apparent trigger for the front round vowel [y]. Rather than assume a phonemic front round vowel, it is possible to regard such forms as underlyingly /tuɸtɸɛ/, with full merger of the sequence /ui/ into [y]. Here, too, the underlying front vowel is not followed by a round element.⁷

3 Syllable shapes

⁷ Other hypothetical options for the apparently illicit /tuɸtɸɛ/ are diphthongization *[tɸjɸɛ] or epenthesis *[tuɸtɸɛ]. We have not found a diphthong [uj] or a sequence [uwi] in our corpus. In contrast, there are occurrences of [ju], presumably from /iu/, e.g. [ju] ‘name of river’. We return to these issues in the section 3.4.

3.1 General

Syllables in Tuwari are all open. No codas are attested (outside those resulting from optional syncope, see 3.3). Initial onsets are not obligatory, though words beginning with /a/ may also surface with an onset [ʃ] (or less commonly [ʔ]), even phrase-initially; we have not found [ʃ] before other vowels word-initially. All consonants can serve as initial onsets.

(17) a. Onsetless words	b. Words with initial onsets
[atɔ] ~ [ʃatɔ] ‘to hold’	[pamo] ‘before’
[ofa] ‘today’	[popo] ‘papaye’
	[so] ‘time’
	[towu] ‘night’
	[mowuatɛ] ‘to hang’
	[joluwa] ‘two’
[ɛni] ‘rope’	[kɛ.mja] ‘pandanus’
	[φɛφɛ] ‘taro’
	[hejsɛ] ‘woman’
[u.njanɛ] ‘confluence’	[tuwɛ] ‘piece’
	[nuwanɛ] ‘to carry’
	[waφɛ] ‘downstream’
[ina] ‘slow’	[pipihɛri] ‘rough’
	[sinapi] ‘crocodile’

We assume that the glide in ‘pandanus’ is syllabified with the preceding consonant. Otherwise, that consonant would be a coda - a rare configuration in Twari.

3.2 Branching onsets

Tuwari also has complex onsets, though only a small set is allowed and not many items have been recorded. All complex onsets are biconsonantal. [h] is excluded from the first C position (C1). In tautomorphemic complex onsets, the second C (C2) can be a glide [j], though not with C1 [p,k]. A C2 [w], in turn, is very rare, and was recorded only after [s,t]. The restricted distribution of glides in C2 suggests that they are not phonemic.

(18) /mio/	[mjo]	‘down’
/kemia/	[kemja]	‘pandanus’
/φia/	[φja]	‘straight’, ‘arrow’
/pesia/	[pesja]	‘fetch’
/sueφɛ/	[sweφɛ]	‘stomach’
/tuasi/	[twasi]	‘twelve’

More commonly, C2 is the liquid. One commonly finds labials [p,ϕ] preceding it. More rarely, one also finds [k,t,s] as C1. The sonorants [m,n] cannot precede /l/ in tautomorphemic sequences:

(19) Examples of branching onset with C2 = /l/

[pɾ]	[tɛpra] ‘viscera’; [apɾo] ‘breast’; [pɾəsaj] ‘first boy’
[ϕɾ]	[jɛϕra] ‘canoe’, [oϕɾɛj] ‘turn’, [waϕɾo] ‘lay’
[kɾ]	[kria] ‘fifth daughter’
[tɾ]	[totru] ‘cold’
[sɾ]	[kɛj.sɾo] ‘turtle’

Finally, in a handful of examples, [n] can serve as C2 after [m] and [s].

(20) [mn]	[mnɛϕu] ‘testicle’
[sn]	[snaɛtja] ‘five’

We also found the sequence [ps] in one - very common - word [opsono] ‘village’.⁸

(21) Branching onsets in tautomorphemic sequences

C1 \ C2	w	j	l	n	s
m	-	+	(+)	+	-
ϕ	-	+	+	-	-
p	-	-	+	-	+
s	+	+	+	+	-
t	-	+	+	-	-
k	+	-	+	-	-

All complex onsets obey the Sonority Sequencing Principle. In heteromorphemic sequences, one also finds the sequence [mr ~ ml], e.g. [m-re] ‘pro-pl’, as well as [m] preceding [w], e.g. [m-we] ‘pro-m.sg’.

Having said all of the above, there is reason to think that most complex onsets are created by the phonology, rather than being lexical. For each of the pairings (but not for every lexical item), we found tokens of the same word either with that sequence or with a vowel between the two consonants:

⁸ We cannot be certain as to the surface syllabification of forms like [opsono]; we assume it is [o.psono] because codas are very rare in Tuwari.

- (22) [sn] [sinaɛtja] ~ [snaɛtja] ‘five’;
 [ps] [opusono] ~ [opsonɔ] ‘village’
 [sr] [sorɔ] ~ [srɔ] ‘time’
 [kr] [kria] ~ [kerja] ‘fifth daughter’⁹
 [tr] [totoro] ~ [totru] ‘cold’, /ateli/ ~ [atri] ‘to cut grass’
 [pr] [aporo] ~ [apre] ‘CMPL’
 [sw] [nasuwaj(a)] ~ [naswaja] ‘where’

Only with [pr, fr, sr] did we find specific items that never varied with a heterosyllabic [CVI].

Importantly, the quality of the optional vowel preceding the liquid or nasal is somewhat predictable. First, it is never the low [a]. Second, for [o/u] to occur in that position, either the next or the preceding vowel has to be round. This suggests that at least some of these consonant sequences are separated by an “empty” vocalic position that may or may not be realized (through the epenthesis of a mid or high vowel). Epenthesis is optional because a branching onset *can* be created in the language

This proposal can be analyzed within the formal framework of Strict CV (Lowenstamm 1996, Scheer 2004), in which all skeletons are construed as the iteration of CV units. (23a) is thus the underlying representation of the word ‘time’ from (22). The empty nucleus has to be accounted for, and one solution is to create a branching onset as in (23b): in Strict CV, branching onsets are regarded as cases of Infrasegmental Government, represented by ← and assumed to silence the nucleus over which they hold. It would seem, however, that the creation of Infrasegmental domains is variable, and another alternative exists, namely copy epenthesis (23c), whereby the nucleus is filled by copying the features of a following vowel (signaled by “>”).

(23) Variable branching or broken onsets

a.	C	V	C	V	b.	C	V	C	V	c.	C	V	C	V
	s		l	ɔ		[s ←		l]	ɔ		s >		l	ɔ
	/slɔ/					[srɔ]					[srɔ]			

3.3 Syncope/epenthesis

The second author, who did the fieldwork, recorded several texts. Subsequently, he listened to the text with the speakers, who repeated the words more slowly. As a result, we have two transcriptions: one corresponding to unguarded natural speech, and the other to slow speech. We noticed several cases in which vowels were present in slow speech, but absent from the recorded text. This is what we refer to here as syncope.

⁹ The syncope produces a difference in gliding between the two: the branching [kr] in [kria] (from /kria/) prevents the gliding of /i/ ([kri.(j)a], *[krja]), whereas the absence of syncope optionally results in gliding [ke.rja]

Most cases of syncope involved the vowel [e/ɛ]. It seems that this vowel can syncope, in monomorphemic sequences and between words, in two configurations. First, if the preceding consonant is a sonorant [m,n, r/l] or an [s] (24a); and second, if the consonant flanking it has the same place of articulation (24b). More rarely, we recorded cases of syncopated [i] and [o] (24c). In (24), the first column gives the slow speech, the second the unguarded natural speech, and the last one the translation. A morphemic gloss is given below the slow speech when useful.

(24) (a)-	mo-tofu	ɤsete-ne	i-mwi-j	motofu ɤs_tene imwij
	SEQ-arrive	hide	go-M.SG-FIN'	'walk hiding'
-	hɛni-ɤane	meri	hɛniɤan_meri	'talk so'
	'this-like talk'			
-	wameta-ɤaprɔ	-nami	wam_taɤaprɔnami	'having removed'
	remove-CMPL	-after		
-	nɛheresa		nɛher_sa	'buy'
(b)-	zezepɛ		z_zepɛ	'saucepan'
-	sapɛ-me		sabmɛ	'raft-VIII.SG'
-	wafɛma		waf_ma	'downriver-DIR'
(c)-	irajti-mi	saɸu	irajtim_saɸu	'dig rice'
	'rice-XII.SG	dig'		
-	onoma		on_ma	'to the house'
-	sipi-mi		sip_mi	'ship-XII.SG'

It can tentatively be argued that the syncopated vowels are in fact epenthetic, and epenthesis occurs in careful speech more than it does in natural speech. The argument is supported by the fact that the quality of the vowel is predictable. In both (a) and (b), where the vowel in question is [ɛ], the preceding vowel is [a]; and in (c), the preceding vowel is not [a], and corresponds in quality to the syncopated vowel.

If this analysis is correct, the position of the alternating vowel will be underlyingly empty, as in (23) above, and then filled by a phonological process of copy epenthesis in the case of a preceding [i] or [o], and by [ɛ] epenthesis in the case of a preceding [a]. In support of this analysis of copy epenthesis, note that the last word in (24) is based on Tok Pisin [sip] 'ship'.¹⁰ Under this view, the cases in (24) are in fact not examples of syncope, but of epenthesis not occurring in fast speech.

¹⁰ Another instance of the same phenomenon is shown by Tok Pisin [balus] 'plane' > Tuwari [balusu]. A similar logic of epenthesis is found in Modern Farsi, where the initial branching onsets of loanwords are broken by a copy of the following vowel, except if that vowel is [a], in which case they are broken by [e]. FR /flyt/ => [fulut], ENG /trɪp/ => [tirip], but ENG /krʌntʃi/ 'crunchy' => [kerɔntʃi], and FR /trɛ̃/ 'train' => [teran] (Jaferian 2024).

3.4 Hiatus

Tuwari tends to avoid hiatuses. This was already shown above for cases of pharyngeal insertion between two low vowels. The same is apparent in other VV sequences, where a hiatus will be resolved either through forming a glide from an adjacent vowel that is still maintained or through the complete gliding of a vowel.

- (25) a. /nofua/ => [nofuwa] ~ [nofuʕa] ‘leaf’
 b. /houaau/ => [howaau] ~ [howaʕau] ‘clean’
 c. /nonoati/ => [nonoati] ~ [nonoʕati] ‘here(?)’
 d. /uɛʔafɛ/ => [wɛʔafɛ] ~ [wɛʕʔafɛ] ‘mountain’
 e. /iami/ => [jami] ‘snake sp.’
 f. /uiuak/ => [wiwak] ~ [ujuʕa] ‘Wewak (toponym)’

In accordance with the hypothesis that glides are possibly non-phonemic, in (25) we represent them as vowels underlyingly. We note that V1 /u,i/ in word-initial hiatus obligatory glides (e.g. 25d,e). An interesting exception is the loan in (25f), where the gliding of the initial [w] is blocked in one of the attested variants because a following /i/ undergoes gliding¹¹.

As discussed, when V2 is [a], hiatus is often resolved by the formation of a pharyngeal, analyzed above as the spreading of [A]. This pharyngeal is sometimes pronounced more like a glottal stop. In some cases, with the same lexical item, hiatus is either not resolved at all or, if the preceding vowel is high, it is resolved with the homorganic glide of that vowel.

- (26) /nua/ ‘carry’: [nuwa] ~ [nuʕa] ~ [nuʔa] ~ [nua]

If the first vowel is [a], and the second vowel is mid, pharyngeal formation occurs (again, optionally). This follows from the above-mentioned dispreference for glide formation on the basis of a mid-vowel.

- (27) /mina-ɔ/ => [minaʕo] ~ [minaʔo] ‘tree-DET’
 /s_nætia/ => [snaʕɛtja] ‘five’

The same dispreference is apparent when the first vowel is high. In that case, the first vowel will spread and form the corresponding glide.

- (28) /sio/ => [sijo] ‘river name’, *[siwo]
 /nuɛfi/ => [nuwɛfi] ‘dark’, *[nujɛfi]

¹¹ We can only assume that the final syllable in [ujuʕa] results from the metathesis of the last two segments of the source word *Wewak*, once again illustrating the avoidance of codas in this language.

=====

In these cases, one never finds [ʃ]. As mentioned, between two mid vowels, one does find [ʃ].

- (29) /sɛ-ɛ/ [sɛʃɛ] ‘DEM-DET’
 /sumɔɔ/ [sumɔʃɔ] ‘rain’
 /waaloɛ/ [waʃaloʃɛ] ‘alone’

We have not found sequences of /ɛɔ/, a point we comment on below. We also did not find the sequences *eji, *oji, *aji, which could have been expected as a repair for underlying /ei, oi, ai/. Instead, there are quite a few sequences [ej, oj, aj] in the corpus.

- (30)
- | | | | | | |
|---------|---------|-------------|--------|---------|---------|
| /hɛifa/ | [hɛjfa] | ‘vegetable’ | /ɛsɛi/ | [ɛsɛj] | ‘water’ |
| /hailɛ/ | [hajlɛ] | ‘heavy’ | /waai/ | [waʃaj] | ‘one’ |
| /tɔisɔ/ | [tojsɔ] | ‘morning’ | /tiɔi/ | [tiʃɔj] | ‘nine’ |

This distribution suggests that sequences like /ei, oi, ai/ are obligatorily converted into the diphthongs [ej, oj, aj]. The view of these as diphthongs, as opposed to VC sequences, is in accordance with the fact that Tuwari does not have codas.¹²

Interestingly, [aji] sequences *are* attested, but the glide in those is always the result of a vocalized /l/: /sinali/ ‘sweet potato’ => [sinaji].

The opposite holds for the high back sounds [u,w]. By analogy to /i/, for non-high vowels followed by /u/, one would expect [ew, ow, aw]. We only found the latter two, and always before another round vowel [u]:

- (31) [ʃinowu] ‘snake sp.’
 [mɛʃaʃawu] ‘fight’
 [motawu] ‘having cut’

This distributional fact suggests that in all those cases, the [w] is a hiatus breaker based on the following round vowel. The impossibility of non-prevocalic [w] in Tuwari suggests that there is a greater need to preserve its status as a nucleus, as opposed to /i/.¹³

We did not find [e] before either [u] or [w]. One possible generalization is that there is a neutralization of the rounding contrast between /ɛ/ and /ɔ/ in favor of /ɔ/ in front of round vowels. This would also explain the fact that [ɛɔ, ɛʃɔ] are unattested.

Other VV sequences that have not been found in the corpus include [iju] and [uwi], implying two high vowels. For these cases, we hypothesize that the gliding of one of the vowel ([ju, wi]), is preferred

¹² We found recurrent cases of surface geminate [j:]. These are always derived from /ai-io/ through gliding of the two high vowels [ajjo].

¹³ In one case, the following rounded vowel was [ɔ]: [maʃawɔʃɔj] ‘bird sp.’. Here one would expect [maʃaʃɔʃɔj], because /ɔ/ does not usually give rise to glide formation. A possible explanation is the avoidance of consecutive [ʃ]s.

over glide formation (*[iju, uwi]) (it is also preferred over the gliding of the second vowel (*[iw, uj]), which would result in a coda). In other words, a CV pattern is preferred over maintaining the two nuclei. To generalize, hiatus is preferably resolved by glide formation from the nucleus of the second, tautosyllabic vowel (e.g., /Vu/ => [Vwu], /Va/ => [Vʁa]). However, glide formation from mid vowels is strongly dispreferred. Thus, if the second vowel is mid, and the first vowel can glide, then it does (/iɛ/ => [ijɛ]), even though it belongs to a preceding syllable. If there are only mid vowels, a pharyngeal glide is formed based on their element |A| (/ɔɛ/ => [oʁɛ]).

4 Stress

A careful phonetic study of the acoustic correlates of stress in Tuwari has not been undertaken, as such a study would require conditions that can hardly be met in the field. On the basis of our hearing - one of us is a native speaker of Modern Hebrew, where stress is a distinctive property of words - sentences in Tuwari feature an acoustically prominent final syllable. This may be the effect of final lengthening. When one examines spectrograms, no syllable seems to carry special pitch or intensity. For instance, the vowels of the word /ani-mo/ ‘rope-DET’ in the screenshot below are roughly equal in both intensity (green) and pitch (blue). The impression of stress in the final syllable is due to its additional length.

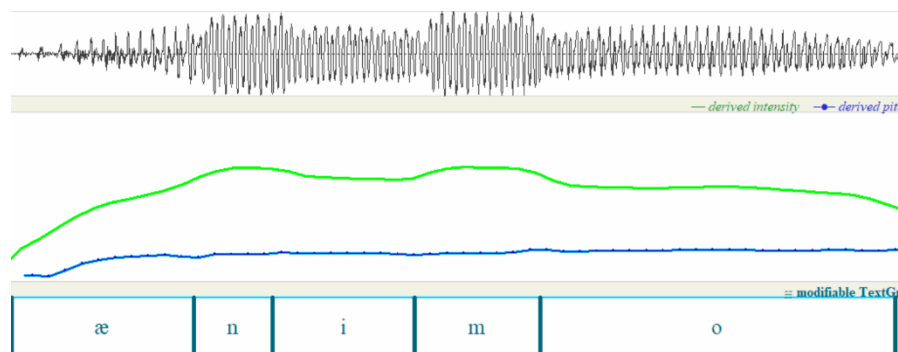

Figure 1. Stress: intensity, pitch and length

A reviewer listened to the text and arrived at a similar conclusion. According to their analysis, stress is often word-final. They also heard secondary stress on every second syllable before main stress.

That as may be, stress does not seem to be an important property of the Tuwari word. There are no minimal pairs that are distinguished only by prominence. Particles, especially /-io/, can be either stressed or unstressed at the phrase edge, seemingly with no real pragmatic effect. In addition, apocope often targets the final vowel of non-phrase-final words, suggesting that stress is not important enough to protect vowels from being elided.

5 Conclusion

This paper presented the phonology of the Tuwari language, a language of Papua New Guinea which has not featured in previous research. Like many of its neighboring languages, Tuwari is characterized by a

small set of phonemes, several of which have at least two allophones. We proposed a symmetry-oriented formalization of the consonantal inventory in terms of binary features which motivates several empty cells by designating the feature combinations that they embody as “marked”. Despite the small number of consonants, and despite the clear phonetic presence of glides, we further argued that glides are not phonemic in Tuwari: they are non-nuclear vowels.

In addition to the limited number of consonantal phonemes in Tuwari, syllable structure in the language is very simple, with no stable codas, internal or final. The consonant clusters that do surface always result from the optional non-realization of underlying vocalic positions between two consonants, which can be analyzed as either syncope or under-application of epenthesis. Interestingly, the clusters that surface are mostly the least marked clusters cross-linguistically: obstruent-liquid “branching onsets” and sonorant/sibilant-obstruent “coda-onset” clusters.

One aspect of syllable structure in Tuwari that does exhibit much phonological activity is hiatus resolution. Since the language allows for onsetless syllables, but tends to resolve hiatuses on the surface, an intricate hierarchy of hiatus resolution strategies emerges. For instance, high /i,u/ and low /a,ɔ,ɛ/ can glide to introduce an onset for their syllable /ia/=> [i.ʃa], and that will be preferred to vowels gliding outside their syllable, e.g. /ia/ => [i.ja]. But mid vowels preferably do not produce glides, such that /ie/ will be pronounced [ijɛ].

It is in this domain of hiatus resolution that one finds the most surprising trait of the language: the optional but common gliding of the /a/ (and more rarely /ɔ,ɛ/) to produce a pharyngeal [ʕ]. While “pharyngeal vowel quality” has appeared sporadically in description of Papuan languages (Fedden 2011: 84, Jendraschek 2012), so far no Papuan language has been found to exhibit pharyngeal consonants. As in other languages with gutturals, the presence [ʕ] often lowers and unrounds surrounding vowels (Walker & Rose 2015).

Independently of [ʕ], the five vowels of Tuwari often interact with each other. Although precise generalizations await more in-depth research, it certainly appears that there are clashes and co-occurrence restrictions between unrounded and rounded vowels, which sometimes produce front rounded allomorphs.

Not only the phonology of Tuwari awaits further study; there is still much work to be done on the morphology and lexicology of the language, as well as on syntactic structures.

6 Abbreviations

I-XIII: class-agreeing article; ADVLZ: ‘adverbializer’; Cmpl: ‘completive’; COP: ‘copula’; DEM: demonstrative; DET: determiner; DIR: ‘directional’; DUR: ‘durative’; FIN: ‘final verb’ (ie. verb of the main clause in a clause chaining construction) or any clause-level constituent; IRR: ‘irrealis’; MED: ‘medial verb’; POSS: ‘possessive’; PRF: ‘perfective’; PST: ‘Past’; PL: ‘plural’; SEQ: consecutive; TOP: ‘topic’; UNSPEC: ‘unspecific’.

Acknowledgments: We thank the two very helpful reviewers for their detailed reviews. This work was made possible through the commitment of the Tuwari speech community to the documentation of their language and their unfailing kindness and support throughout the fieldwork.

7 References

- Angoujard, Jean-Pierre. 1995. Quelques ‘Éléments’ pour la représentation des gutturales. *Langues Orientales Anciennes : Philologie et Linguistique* 5-6. 107-126.
- Backley, Philip. 2011. *Introduction to Element Theory*. Edinburgh: Edinburgh University Press.
- Evans and Fedden to appear. *The Oxford Guide to the Papuan Languages*, Oxford: Oxford University Press.
- Faust, Noam & Nicola Lampitelli. 2026. Guttural syneresis in Tigrinya and Tigre. *Glossa: a journal of general linguistics* 11(1). doi: <https://doi.org/10.16995/glossa.24525>
- Fedden, Sebastian. 2011. *A grammar of Mian*. Berlin: De Gruyter Mouton.
- Foley W. 1986 *The Papuan languages of New Guinea*, Cambridge University Press, Cambridge.
- Jaferian, Alireza 2024. *Questions de phonologie persane : structure syllabique et processus phonologiques*. Paris: Université Paris 8 PhD dissertation.
- Jendraschek, Gerd. 2012. *A grammar of Iatmul*. Regensburg: Universität Regensburg Habilitationsschrift.
- Kaye Jonathan, Jean Lowenstamm & Jean-Roger Vergnaud. 1985. The internal structure of phonological elements: a theory of Charm and Government. *Phonology Yearbook* 2. 305-328.
- Kokkelmans, Joachim. 2021. *The phonetics and phonology of sibilants: A synchronic and diachronic OT typology of sibilant inventories*. Verona: Università degli Studi di Verona PhD dissertation.
- Loiseau, Sylvain. Forthcoming. Tuwari Cameo. In Evans Nick & Sebastian Fedden (eds.) *The Oxford Guide to Papuan Languages*. Oxford: OUP.
- Lowenstamm, Jean. 1996. CV as the only syllable type. In Durand, Jacques & Bernard Laks (eds.), *Current Trends in Phonology. Models and Methods*. Salford, Manchester: Esri. 419–441.
- Lowenstamm, Jean & Jean-François Prunet. 1985. On Certain Nominal Patterns in Tigrinya. *Proceedings of the 15th Conference on African Linguistics*. Foris, Dordrecht.
- Riggle, Jason. 2011. *Phonological Features Chart* v.11.02. Retrieved online 10/02/2026.
- Scheer, Tobias. 2004. *A Lateral Theory of Phonology: What is CVCV and why should it be?* Berlin, New York: Mouton.
- Walker, Rachel & Sharon Rose. 2015. Guttural Semi-Transparency. Unpublished handout of talk given at AMP 2015, Vancouver, October 10, 2015.

8 Short text

The text was recorded in 2015 and features a female speaker in her 40s recounting a family excursion into the forest to harvest a sago tree. The first line displays the narrow phonetic transcription produced for this study. The second line represents a transcription of a slow, careful speech version by the speaker, recorded during fieldwork while she listened to her original recording. As a result, in some places the two texts do

not match (for instance due to a pronoun inserted in slow speech). The third line provides the morphemic breakdown, and the fourth line provides the morphemic glosses.

The audio recording can be accessed online:

https://tuwari.huma-num.fr/pub/2026LLM/150720_02_Source.WAV

1.

hamwéja	saβo	mtosinami,	mtosinamíjo
hamwejo	sape	mtosinami	mtosinamijo
ham-we-io	sa-pe	me-tosi-nami	me-tosi-nami-io
PN-M.SG-FIN	raft(VIII)-VIII.SG	SEQ-build-after	MED-build-after-FIN

tajo	munwurunamía	tawsíw	mjowajo
tajo	munulunami	tajsɔ	mjowajo
ta-io	munɛlu-nami-io	toisɔ	miɔ-ia-io
1PL-FIN	sleep-after-FIN	morning	down-PST-FIN

'After Ham had built a raft and we had slept, we went downstream the next morning.'

2.

mjonami	mjose	mjoze	mjaze...	mehemjowajo
mjonami	mjose	mjose	mjose	mehemjowajo
miɔ-nami	miɔ-se	miɔ-se	miɔ-se	me-hei-miɔ-ia-io
down-after	down-DUR	down-DUR	down-DUR	SEQ-paddle-down-PST-FIN

sab	mehemjowajo
sape	mehemjowajo
sa-pe	me-hei-miɔ-ia-io
raft(VIII)-VIII.SG	SEQ-paddle-down-PST-FIN

'We went down and down, paddling, paddling the raft.'

3.

sabme	mjose
sape	mjose
sa-pe	miɔ-se
raft(VIII)-VIII.SG	down-DUR

bush-tree SEQ-cut-after-FIN 3-SG.M tree_sp-tree-PL cut-3-SG.M-FIN

'After we cut the grass, Ham cut some hoo trees.'

6.

miterele	mφejnami	mu	melijo
mitlele	φejnami	mwe	melijo
mi-tlopla-le	φei-nami	me-we	meli-io
tree-pole-PL	cut-after	POS-3SG.M	talk-FIN

hejo	ta	unaínu	wíʃanəmraja
ejɔ	ta	unajnu	jaanemeliʃajɔ
eiio	ta	u-nai-nu	iaamela-io
EXCL 1PL	sleep-IRR-LOC	correct-FIN	

'Once he had cut some poles, he said : "We will sleep good".'

7.

mimuwa	ʒa	tiʃabí		menenamija
meijmwe	a	tiapi	nɛhɛ	menenami
meimwe	a	tiapi	nɛhɛ	me-nɛ-nami
then	1SG	knife	DEM	SEQ-catch-after

miʃamlaze	mowaφoφej	senami
miʃamlase	muaφeφej	sinehɛ
miamle-se	muaφeφei	si-nɛhɛ
look-DUR	clean	land-DEM

'Then I took a machete and went looking for a place to clean.'

8.

otaʃu	naʃanφja	minamijo
otau	naanɛφiale	menamio
ɔtau	naanɛφiale	meinami
cut	remove	after

mnaʃaneφrealemrenami	minele	tejjo	mo	mitrole	tataʃa	φialejɔ
naanɛφelimɛnami	minele	tejɔ		metlole	taataa	φiʃalejɔ

naaneφiale mēinami minε-le tēi-iō mitlō-le taa-taa φiai-iō
 remove after branch-PL go-FIN pole-PL side-side plant-FIN

'After I had cut the trees and cleared the place, removing the branches, I planted the poles side by side.'

9.

Mitolō tea taφα mφiarinamiō
 mitlō taa-taa φiai-iō-nami-iō
 pole-PL side-side plant-FIN-after-FIN

tajō selehε jō sεrehεjō φúhanówwō
 ta-iō sele-he sele-he φu-anō-u-iō
 1PL-FIN plastic-IV.SG plastic-IV.SG put-spread-stay-FIN

'After I had planted the poles, we laid the plastic roof over them and unfolded it.'

10.

seleneheje taφαφαφúha taφαφαφúhamōnamje tajtimi mínamijō
 selenehe tahahaφuwa taiti mφimanamiō
 sele-nehe taa-φu-ia taa-φu-ia mejnami taitim me-φima-nami-iō
 plastic-DEMSide-put-PST side-put-PST after stretch SEQ-?-after-FIN

'After we had fixed the plastic on each side, we stretched it.'

11.

 hezebídja neriō ta melijō ta hajdemla ?anuwo
 maaaplōne εjsōpitijanelijō ta melijō ta hejtōmle anōwō
 maa-aplō-ne heisepitia-neli-iō ta meli-iō ta heitōmu-le anō-iō
 one-finish-MED girl-DU-FIN 1PL talk-FIN 1PL food-PL want-FIN

'Once this was finished, our daughter tell to us : "we shall eat"'

12.

hedōmla fanomulo mēejō
 hejtōmle anōmuwo mlejō
 heitōmu-le anō-mu-iō mle-iō
 food-PL want-?-FIN 3PL-FIN

“*We are all hungry.*”

13.

ʒa	meli	temline	waʒajaliʒa	janulu	jowu	naʒanuna	ʒaʔywo
a	meli	temline	waajale	janule		nuwane	aʔuwɔ
a	meli	temline	waai-ale	ianu-le		nua-ne	a-ʔu-iɔ
1SG	talk	PN	quick-ADVLZ	firewood-PL		carry-MED	go-put-FIN

I said, “Temline, go quickly and fetch some firewood.”

14.

janula	ʒanuama	aʔunamijo
janule	munuane	maʔunamjɔ
ianu-le	mɛ-nua-ne	mɛ-a-ʔu-nami-iɔ
firewood-PL	SEQ-carry-MED	SEQ-come-put-after-FIN

məliʒa	ilajdymi		wmórowo
mle	ilajtumi	jɔwe	mɔlɔwɔ
mle	ilaitu-mi	iɔwe	mɛ-alu-iɔ
DEM:PL	rice-XII.SG	go	SEQ-light-FIN

After she brought some firewood, tey cook the rice.

15.

lajdim	móronami,	moraʒaplənami,	
ilajtumi	mulenami	mulɔaplənami	mɔleaplənami
ilaitu-mi	mɛ-u-le-nami	mɛ-u-lɔ-aple-nami	mɛ-alu-aple-nami
rice-XII.SG	SEQ-stay-PL-after	SEQ-stay-?-CMPL-after	SEQ-light-PRF-after

mətaʒaʔunamijo
mətaʔunamjɔ
mɛ-ɔta-ʔu-nami-iɔ
SEQ-remove-put-after-FIN

Once the rice was on the fire and cooked, she took it off.

mətaʒaʔunamija,	nəmu,	mle	hapɔ,	haʒamwa	tɔdwurajɔ	
m-ɔta-ʔu-nami-ɔ	nɔmu	ta	hapɔ	haɔ-mi	tɔtuɔla-iɔ	
mɛ-ɔta-ʔu-nami-iɔ	nɔmu	ta	mle	hapɔ	haɔ-mi	tɔtɔali-iɔ
SEQ-remove-put-after-FIN	there	1PL	DEM:PL	time	fish-XII.SG	boil-FIN

'And after that, it was time for them to boiled the fish on the fire'.

16.

haʃam tətɣɛɾɛnamija
 haɔmi mətɔtuɔlenamijɔ
 haɔ-mi mɛ-tɔtɔali-nami-iɔ
 fish-XII.SG SEQ-put-after

dodyʃaβlɛnami haʃa... haʃa zzebe senuwa
 mətɔtuɔlenami haɔ sesepeɾenehe
 mɛ-tɔtɔ-aple-nami haɔ sɔsupɛɛ-nɔ-he
 SEQ-remove-PRF-after fish saucepan-DEM-IV.SG

mətarenami wamtaʃaβrɛnami
 metalenami wametaɔplɛnami
 mɛ-ota-le-nami wa-mɛ-ta-aple-nami
 SEQ-remove-?-after back-SEQ-remove-PRF-after

upasimə mtaɸunamija ok noɸuare jowu niajo
 upasima metaɸunamijɔ noɸuale jɔwe neɟajɔ
 upase-ma mɛ-ta-ɸu-nami-iɔ noɸua-le iɔwe nɛ-ia-iɔ
 sand_bank-DIR SEQ-remove-put-after-FIN leaf-PL go catch-PST-FIN

noɸuare
 mesaɸuaplenami
 mɛ-saɸu-aple-nami
 SEQ-dig-CMPL-after

ilajtim misaɸuʃabrɛnami ilajdim saβu ʃaplɛnamijɔ habɔ haʃalɔ
 ilajtu misapuaplenamijɔ hapɔ haɔle
 ilaitu saɸu-aple-nami-iɔ hapɔ haɔ-le
 rice SEQ-dig-CMPL-after-FIN time fish-PL

kɔmnaʃamɔ ɸɣajɔ
 kɔmnama ɸuajɔ
 kɔmna-ma ɸu-ia-iɔ
 top-DIR put-PST-FIN

'After I had taken the fish off the saucepan and placed them on bank stones, I went to get leaves, dug a hole and put the rice in it with the fish on top of it'

17.

haʃa ne komnaʃamo ʃunami,
 haʃ kɔmnama mjɔʃunami
 haʃ kɔmna-ma miɔ-ʃu-nami
 fish top-DIR down-put-after

temlizi maliøqy tejlə ədi waʃaji ona ajo
 temlin-se mali həu eila-tule waai-ale iɔ-na a-iɔ
 temline-se mali həu waai-ale iɔ-na a-iɔ
 temline-F.SG talk shoot quick-ADV LZ down-? go-FIN

'After I put the fish on top, I shouted to Temline: "come down quickly!"'

18.

mejamywə ta waʃaruʃare miw ajo hamətare
 mejamə ta waalwale jəwe mjəwajə
 meiamə ta waai-ale iəwe miɔ-ia-iɔ
 then 1PL quick-ADV LZ go down-PST-FIN

'Then we came down quickly'

19.

minamía ta ilajtinijo haʃarəlo mohomla
 minami ta ejlatule
 minami ta ilajtu-le
 then 1PL rice-PL

mas(ə)le mase mase... masenjə maʃaprenjo
 mase mase maaplenamio
 me-ɔ-se me-ɔ-se me-ɔ-ape-nami-iɔ
 SEQ-eat-DUR SEQ-eat-DUR SEQ-eat-CMPL-after-FIN

tíʃeni táne dɛdólajo
 tíʃeni tanele tɔtɔlajə
 teʃene ta-ne-le tɔtɔ-la-iɔ
 belly 1PL.POSS-PL full-COP-FIN

tyeseleja hejʃəmwiyo mó tonowo
 tuesle hejʃəmə jəwe tənajo
 tue-se-le heiʃə-mə iəwe tənə-iɔ
 half-UNSPEC-PL dog(III)-III.SG go carry-FIN

‘Then we ate the rice—we ate and ate... and after we had eaten completely, with our bellies full, we brought a portion to the dog.’

20.

hejɸu	nuɸaja	haʒalo	ɔmɔjna
hejɸo	nɔɸa	haɔle	ɔmɔj
heiɸo	nɔ-ɸa	haɔ-le	ɔ-mɔ-io
dog(III)	DEM-also	fish-PL	eat-III.SG-FIN

‘The dog in turn ate the fish’.

21.

haʒa	hejtoru	mase	mase...
haɔ	hejtɔmu	mɛ-ɔ-sɛ	mɛ-ɔ-sɛ
fish	food	SEQ-eat-DUR	SEQ-eat-DUR

hejɸu	nɔɸa,	tiɸenəmo	ɸeɸája	tietəmmɔmwijna
hejɸo	nɔɸa			tjetjɔ-lɔ-mwij
heiɸo	nɔ-ɸa	teɸene	?	tlotlɔ-lɔ-mɛ-wɛ-io-na
dog	DEM-also	belly		full-COP-3-SG.M-FIN

teto	ntaɸo	waʒajne	heli
tone	taɸa	waajneheli	
tɛ-to-nɛ	ta-ɸa	waai-nɛnɛ-li	
man-woman-DEM	1PL-also	same-DEM-?	

‘And in turn, the dog ate and ate, hungry of fish he eat and eat... until his belly was full, just like for us the humans.’